

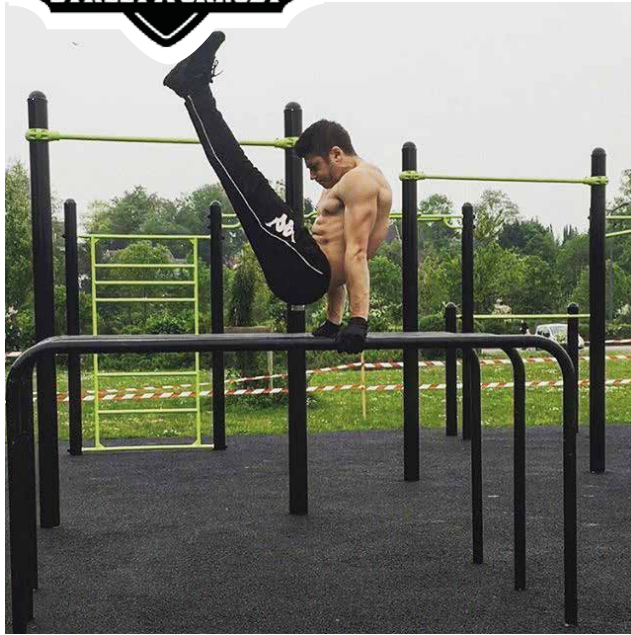

# DAMA Pro

## Dips



- Appareil en acier galvanisé thermolaqué.
- Barres de préhension: Diamètre 48mm épaisseur de l'acier 3.5mm.

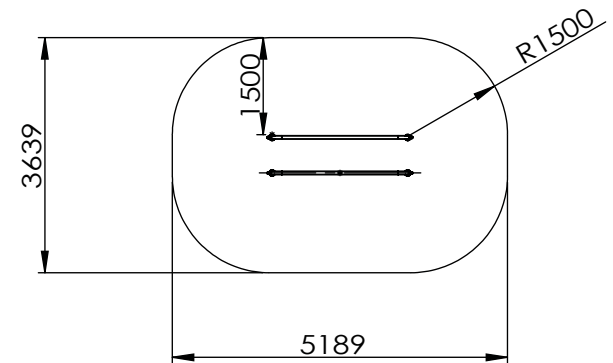
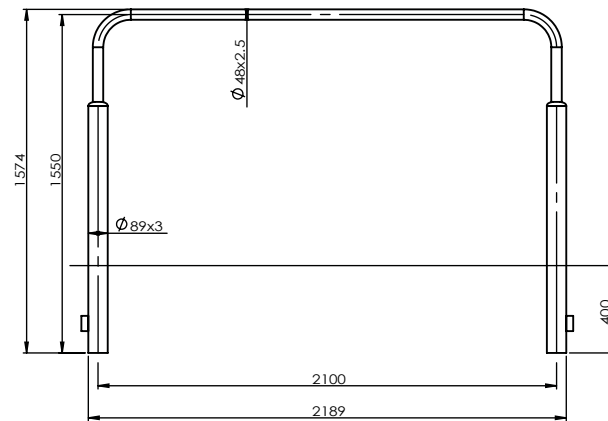
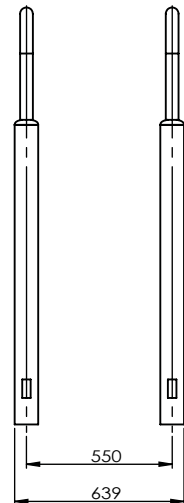

DamaStreetWorkout



www.damapro.fr



# Technique



Angle arrondi pour plus de sécurité et de figures.

Barre de dips 48mm pour une meilleure prise en main, épaisseur de l'acier 3.5mm.

Scellement direct, assemblage très rapide.



## LE DIPS

**Le DIPS permet d'effectuer des exercices pour les triceps, les pectoraux et le dos, mais également des figures acrobatiques.**